

## In-line Flow Conditioning Plates

### Features

- Minimizes low profile irregularities caused by elbows, valves, expansions, reductions
- Significantly reduces upstream and downstream piping requirements
- Low pressure drop
- Available in sizes for 1" to 14" schedule 40 pipe (larger sizes contact factory)
- Rugged 316 ss construction
- Easy installation using customer supplied flanges

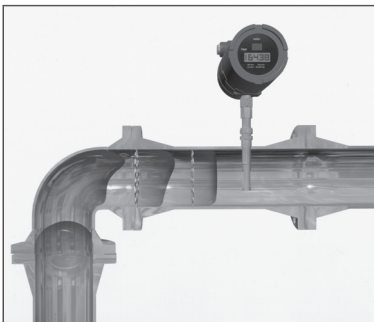

*Built-in flow conditioning creates a uniform velocity profile in constrained applications*

# Flow Conditioning Plates

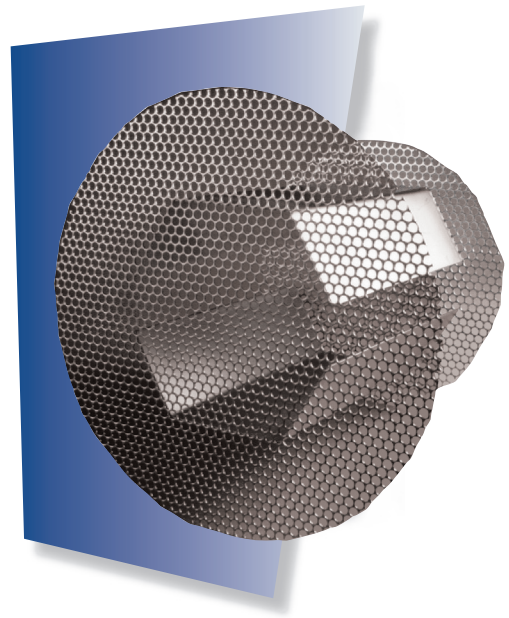

### Description

**S**ierra Instruments' Flow Conditioning Plates represent an economical solution to problems associated with monitoring flow installations where long, straight runs of piping are not available. The flow conditioning element effectively eliminates velocity profile distortions, swirl and temperature stratification in the gas stream. The flow conditioner creates a uniform velocity profile by means of two stainless steel perforated plates. Designed to work in schedule 40 pipe (other schedules contact factory) with 150# flanges, the front flow conditioning screen is sandwiched between two 150# flanges, along with two 1/8" gaskets (gaskets and flanges are supplied by customer). The flange mounting bolts serve to center the screen in place.

The flow plates reduce upstream piping diameters to less than three diameters after most common flow disturbances. Extensive testing has demonstrated that this device virtually eliminates the effect of piping conditions with fewer upstream diameters than any other flow conditioning technique.

Flow plates may be purchased separately for general flow conditioning or they may be used with existing Sierra insertion meters. If used with existing meters, the meter **MUST** be calibrated with the flow conditioning plates in



**SIERRA**  
EXPERIENCE OUR PASSION FOR FLOW!

For information online...  
[www.sierrainstruments.com](http://www.sierrainstruments.com)



The information contained herein is subject to change without notice.

## Dimensional Specifications

### Model 640S

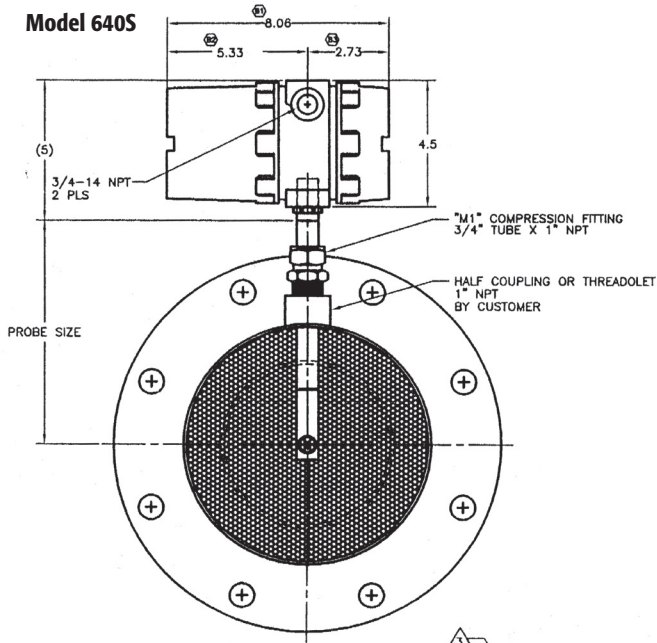

DIMENSION CHART				
PIPE SIZE	"A" DIM	"B" DIM	"C" DIM	PROBE CODE (SIZE)
1" (1.315)	1"	2"	8.34"	L04 (4")
1.5" (1.90)	1.5"	3"	9.05"	L05 (5")
2" (2.375)	2"	4"	8.81"	L05 (5")
3" (3.50)	3"	6"	9.25"	L06 (6")
4" (4.50)	4"	8"	8.75"	L06 (6")
6" (6.625)	6"	12"	8.69"	L07 (7")
8" (8.625)	8"	16"	8.69"	L08 (8")
10" (10.75)	10"	20"	9.62"	L10 (10")
12" (12.75)	12"	24"	8.62"	L10 (10")
14" (14.00)	13"	26"	11.00"	L13 (13")

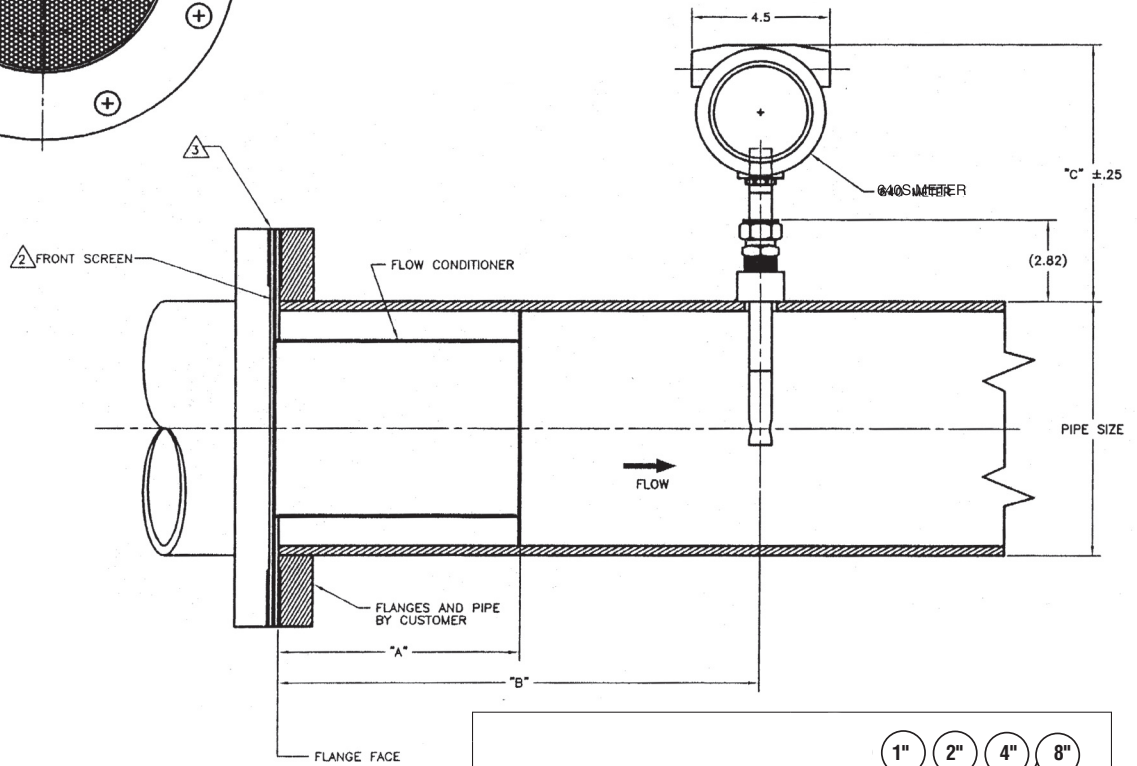

### Required Straight Lengths Relative to Upstream Disturbances

Disturbance	Upstream Diameters	
	Orifice Plate	Flow Cond. Plates
One 90° Elbow	28	1
Two 90° Elbows Same Plane	36	3
Two 90° Elbows Different Planes	62	3
Reducer - 4/1	14	3
Globe Valve - Fully Open	32	2

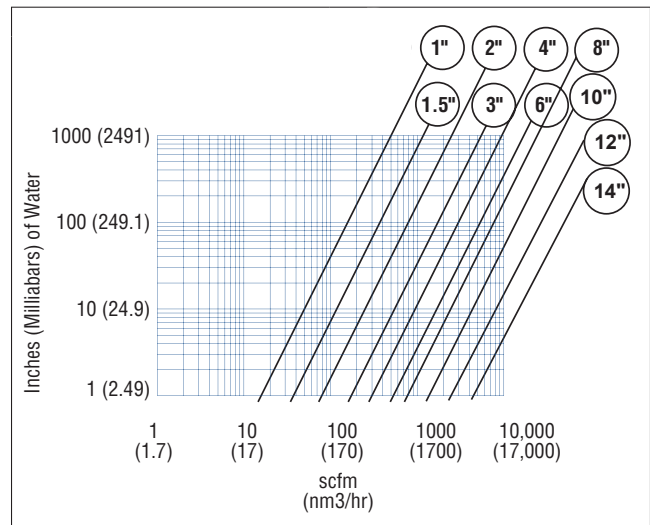

**Note: 10"-14" 87.1 inches of H<sub>2</sub>O @ 20,000 sfpm**